



WOODMARK
Quality System
Système de Qualité



R84.422461

SINGLE RTA MATES BED
LIT D'OFFICIER SIMPLE PAM

ASSEMBLY INSTRUCTIONS
GUIDE D'ASSEMBLAGE

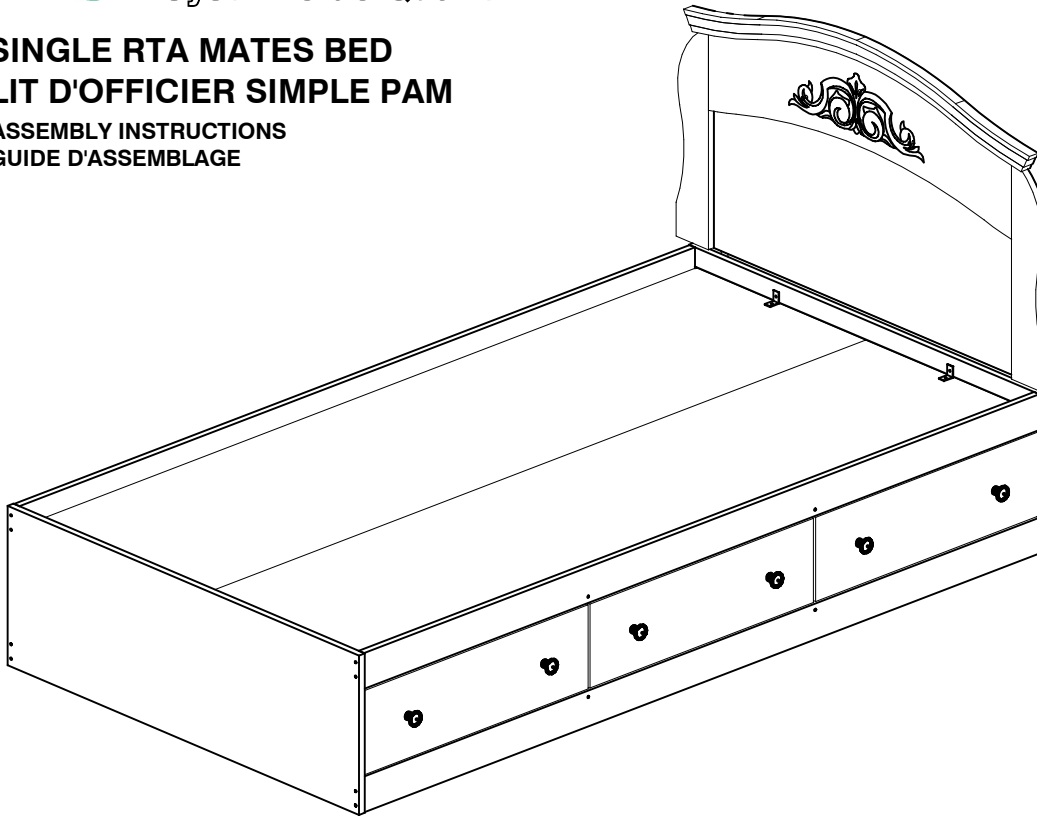

NOTE: ACTUAL PRODUCT NOT EXACTLY AS SHOWN
NOTE: LE PRODUIT ACHETÉ PEUT VARIER DU PRODUIT ILLUSTRÉ

TOOLS REQUIRED

1. PHILIPS #2 SCREWDRIVER
2. HAMMER

OUTILS NÉCESSAIRE!

1. UN TOURNEVIS PHILIPS #2
2. UN MARTEAU

CAUTION / PRUDENCE

DO NOT USE POWER DRILL.
NE PAS UTILISER LA PERCEUSE ÉLECTRIQUE.



IMPORTANT TO OUR CUSTOMER:

THIS PRODUCT HAS BEEN CAREFULLY QUALITY CONTROLLED BUT HUMAN ERROR CAN OCCUR. SHOULD YOU EXPERIENCE ANY PROBLEMS OR HAVE QUESTIONS CONCERNING THE ASSEMBLY OF THE UNIT PLEASE CONTACT CUSTOMER SERVICE AT (403) 236-3220.







SHOULD YOU REQUIRE A REPLACEMENT PART/COMPONENT DUE TO DAMAGE OR IT HAS NOT BEEN INCLUDED; PLEASE CONTACT THE CUSTOMER SERVICE TEAM AT THE STORE FROM WHICH YOU PURCHASED THE UNIT.

IMPORTANT CHER CLIENT:

LA QUALITÉ DE CE PRODUIT EST SOIGNEUSEMENT CONTRÔLÉE MAIS UNE ERREUR HUMAINE A PU SE PRODUIRE. SI VOUS EXPERIECEZ UN PROBLÈME AVEC LE PRODUIT OU AVEZ DES QUESTIONS CONCERNANT L'ASSEMBLAGE DE CETTE UNITÉ, S'IL VOUS PLAÎT VEUILLEZ CONTACTER LE SERVICE À LA CLIENTÈLE AU (403) 236-3220.

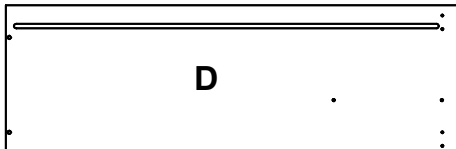
SI VOUS AVEZ BESOIN D'UN REMPLACEMENT D'UNE PARTIE DOMMAGÉE OU UNE PARTIE QUI N'EST PAS INCLUÉE DANS L'UNITÉ, S'IL VOUS PLAÎT VEUILLEZ CONTACTER LE SERVICE À LA CLIENTÈLE DU MAGASIN DUQUEL VOUS AVEZ ACHETÉ L'UNITÉ.

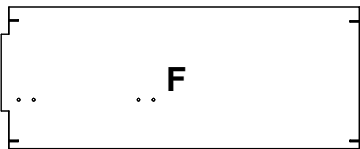
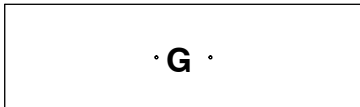
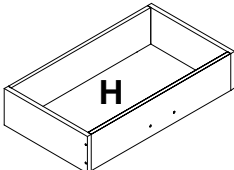
DESCRIPTION	ILLUSTRATION	QTY/QTE	
MAIN ASSEMBLY SCREW (38mm) VIS D'ASSEMBLAGE PRINCIPALE		a	20
SLIDE SCREW (12mm) VIS POUR GLISSIÈRE		b	12
DRAWER BOX SLIDE SCREW (16mm) VIS POUR GLISSIÈRE DE TIROIRS		c	18
COVER CAP CACHE-TROU		d	20
HANDLE SCREW (38mm) VIS POUR POIGNÉE		e	6
"L" BRACKET SCREW (16mm) VIS POUR SUPPORT EN "L"		f	8
HANDLE POIGNÉE		g	6
BACK PLATE PLAQUE MÉTALLIQUE		h	6
"L" BRACKET SUPPORT EN "L"		i	4
BRACE SCREW ACCOLADE VIS		j	4
BRACE WASHER RONDELLE ENTRETOISE		k	4

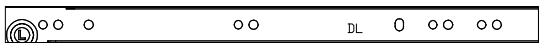
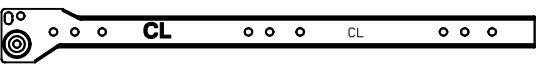
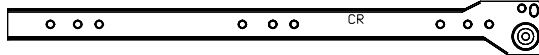
ILLUSTRATION	DESCRIPTION	QTY/QTÉ
	A	1
	B	1
	C	1
	D	1
	E	1
	F	2
	G	3
	H	3
	I	2
	J	3
	K	3
	L	3
	M	3

1

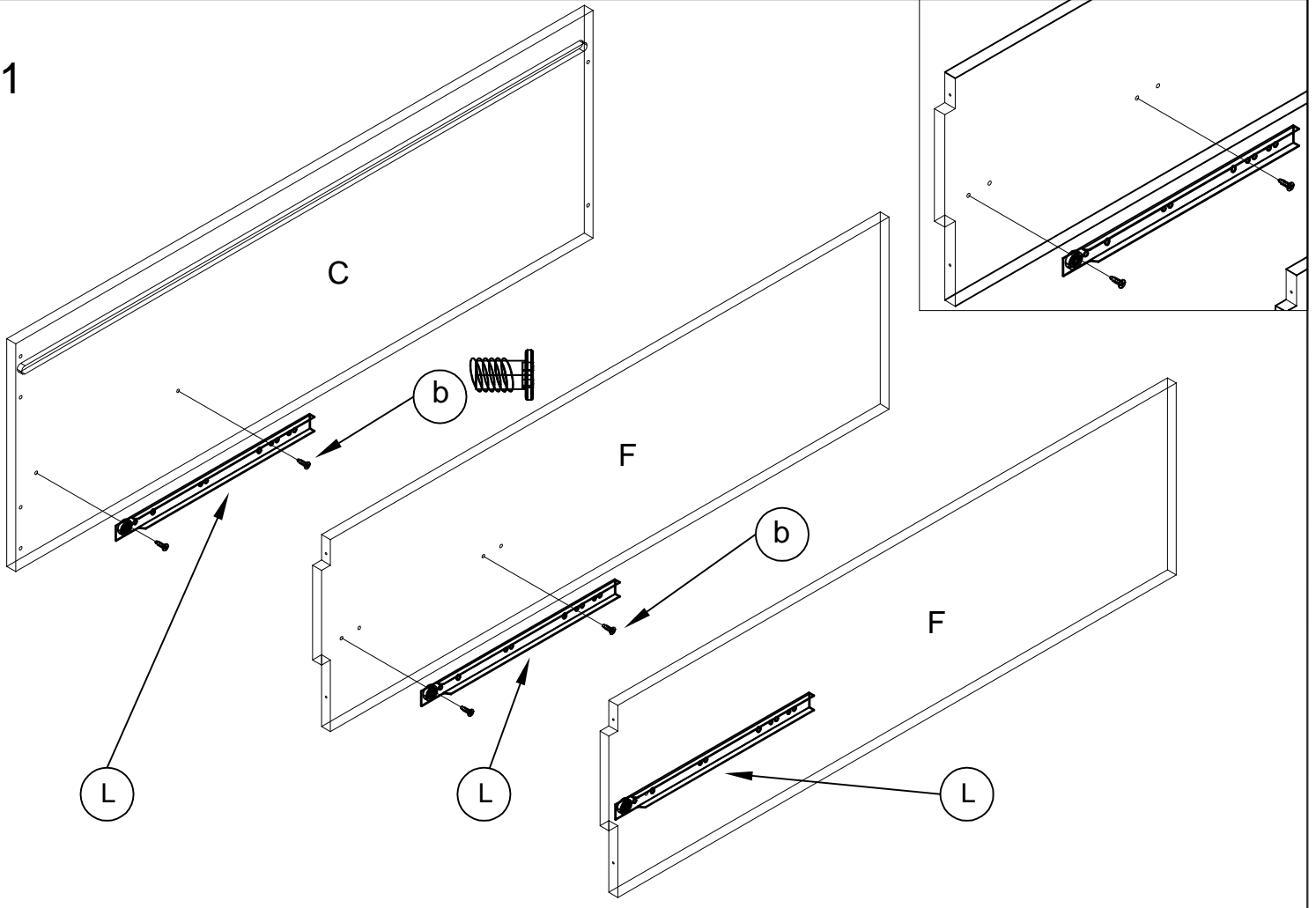

2

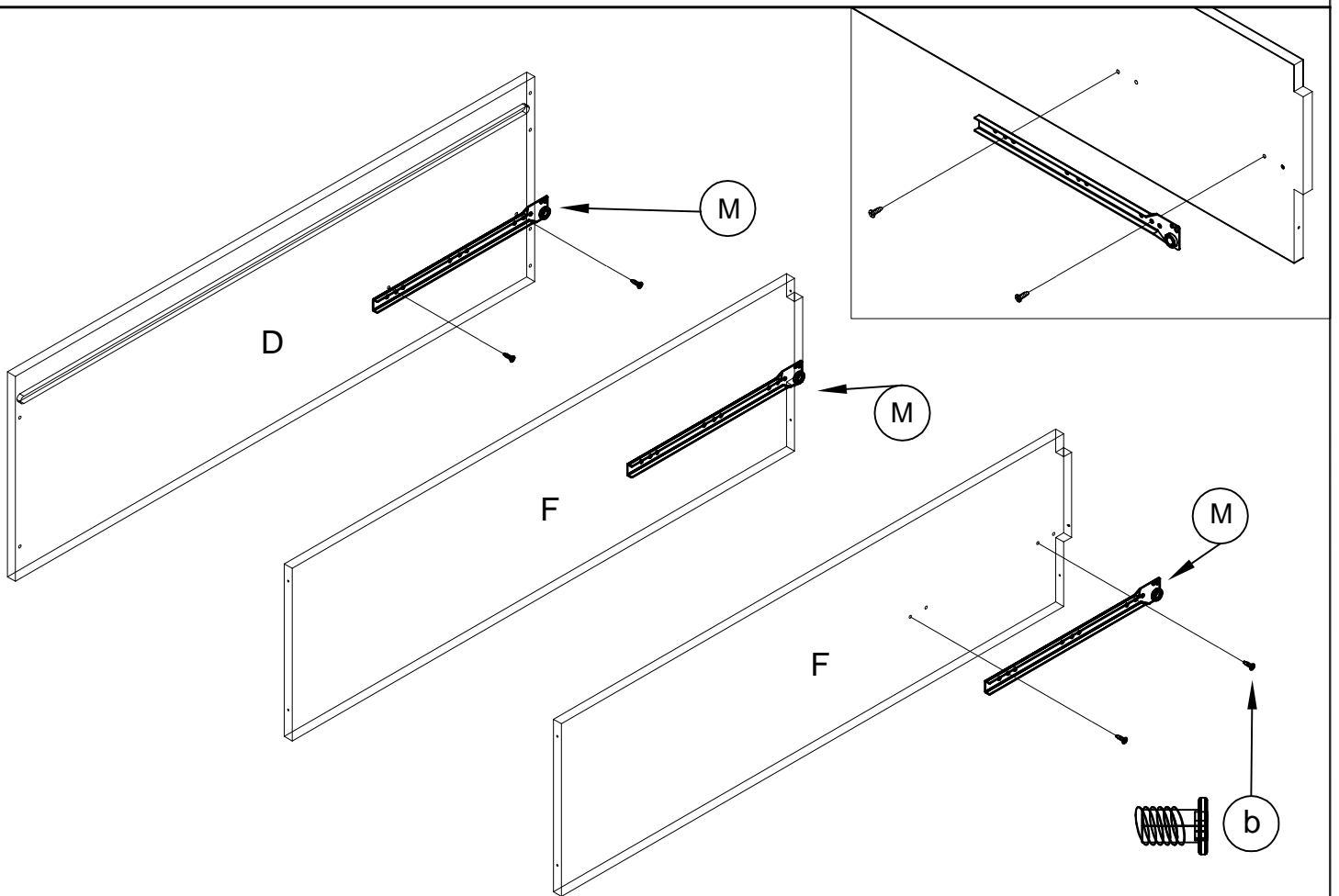

3

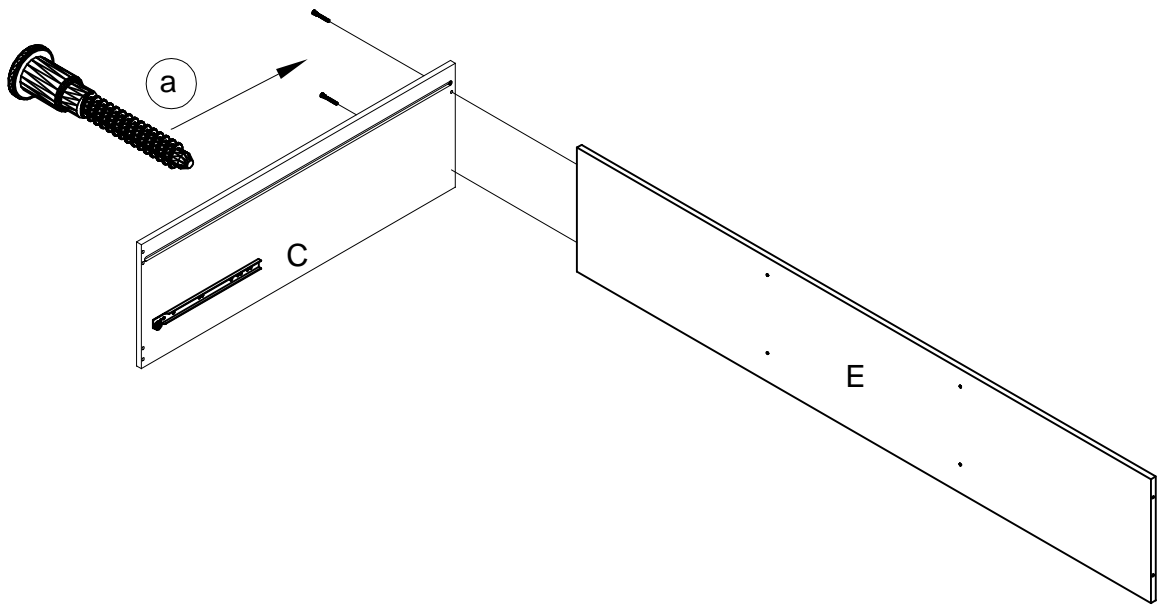

4

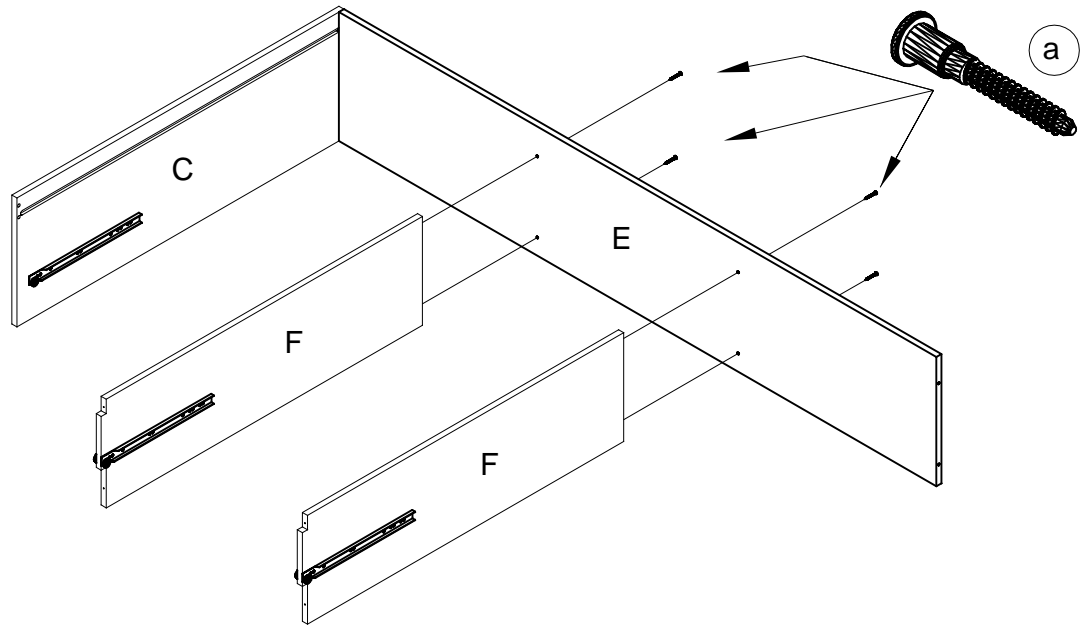

5

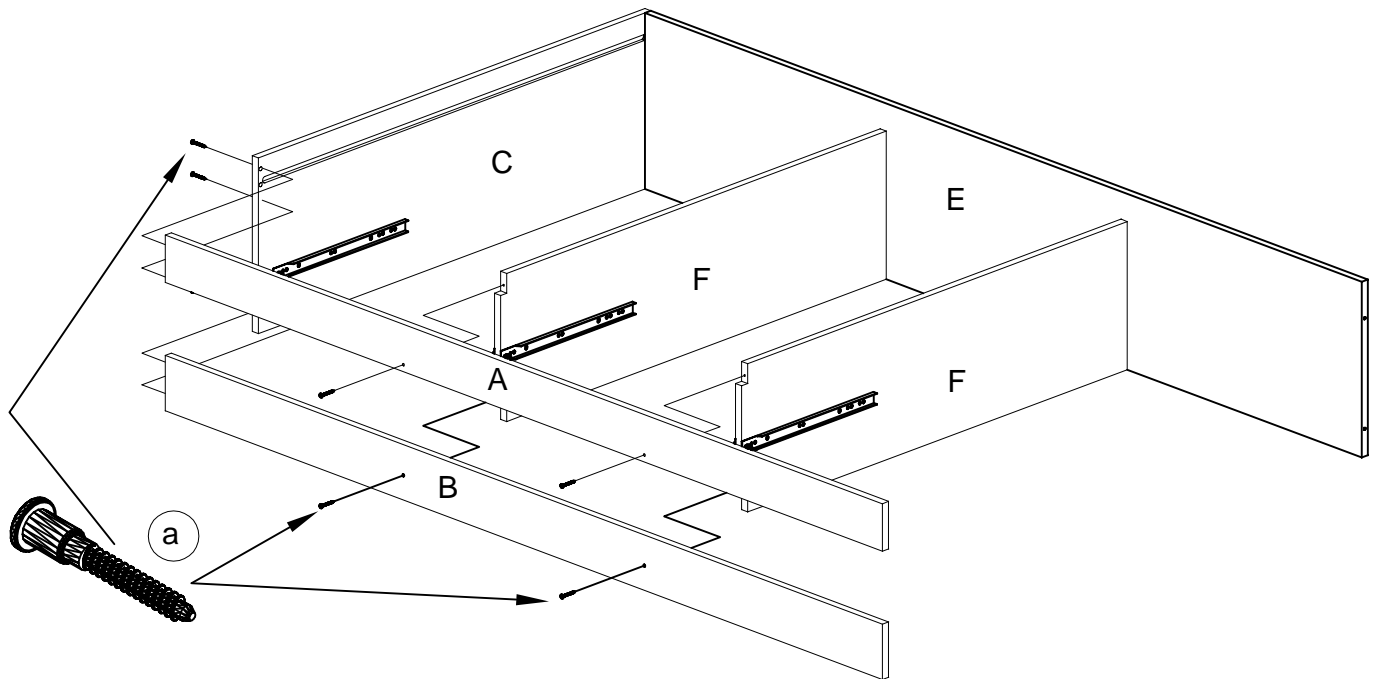

6

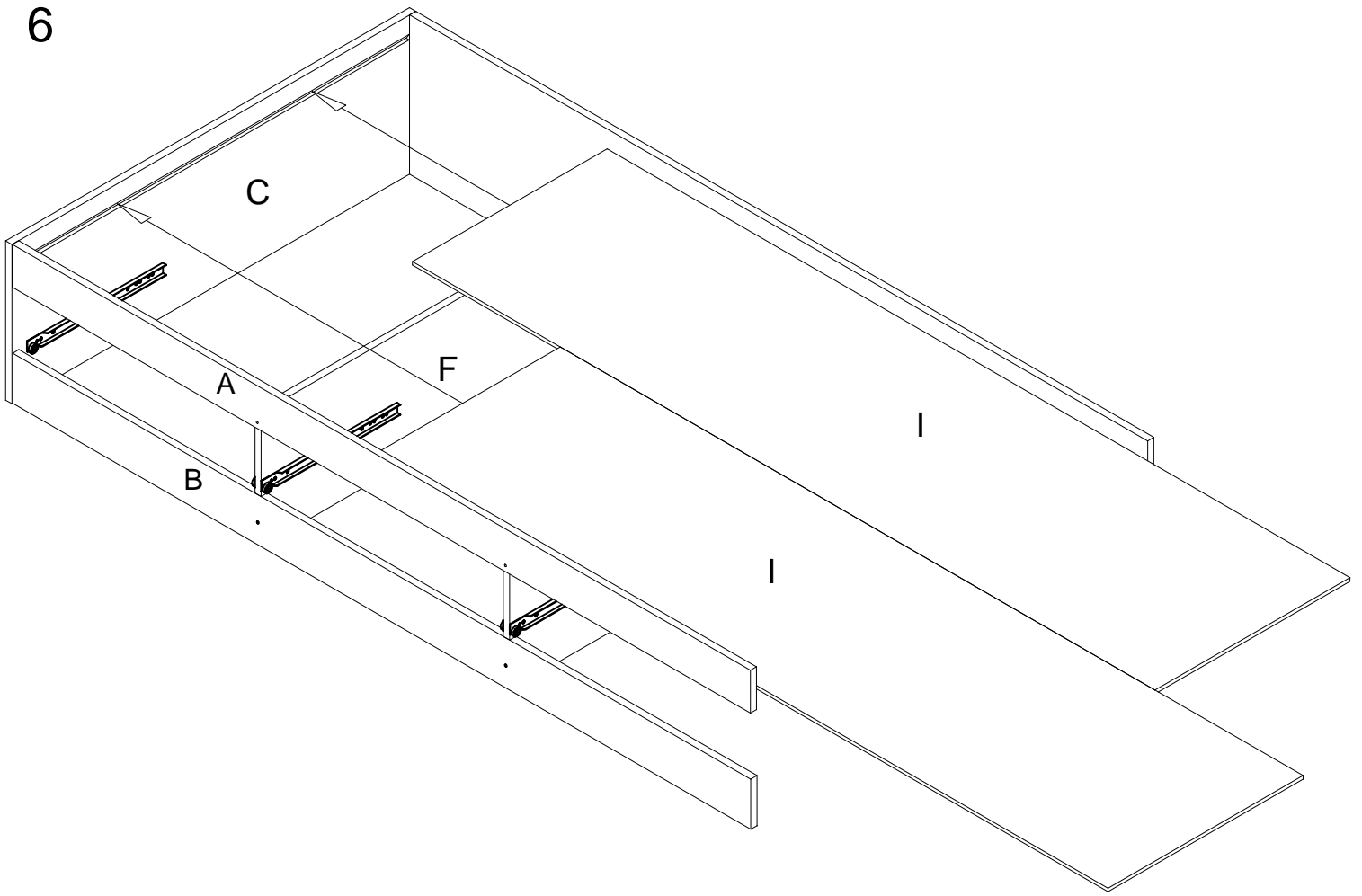

7

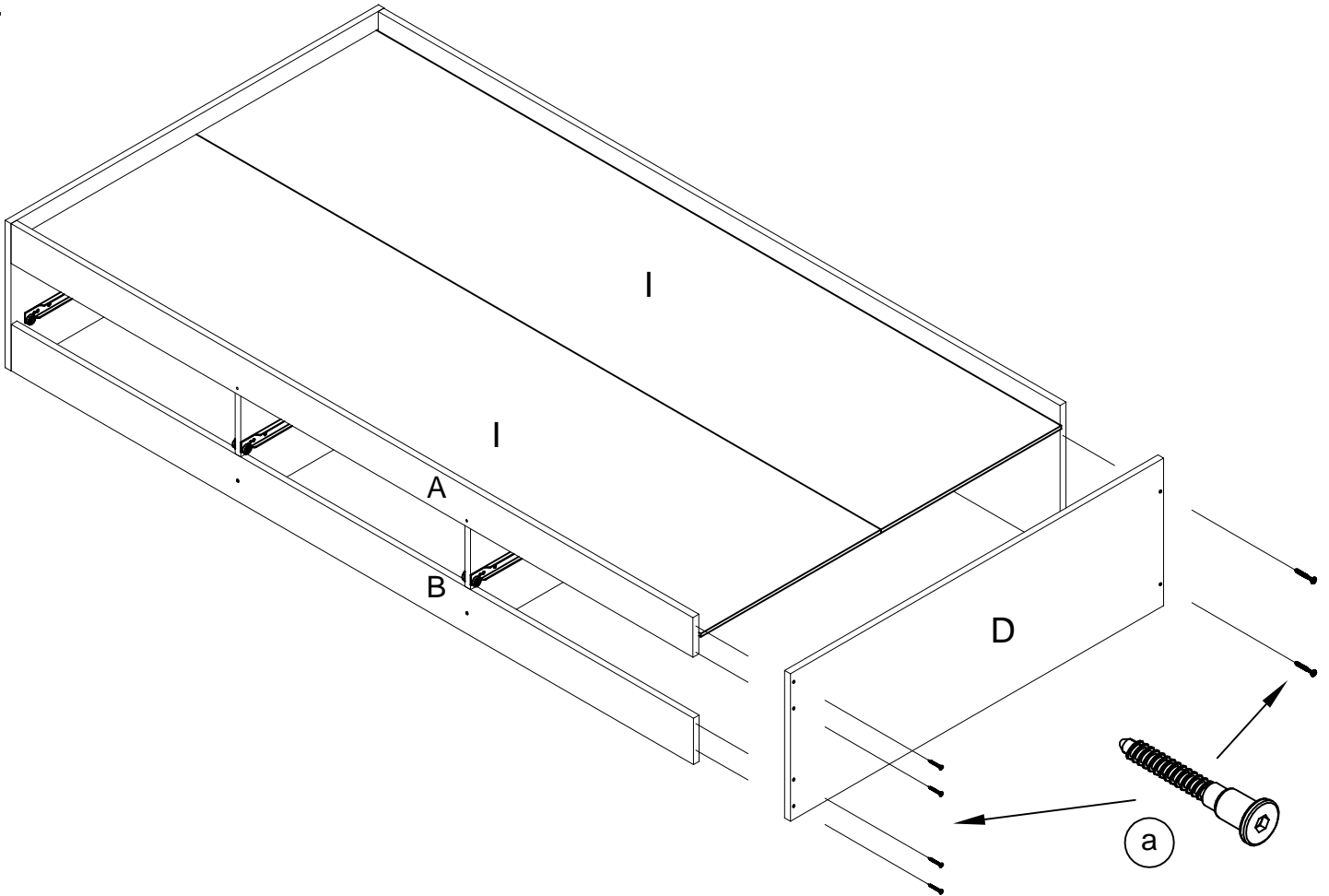

8

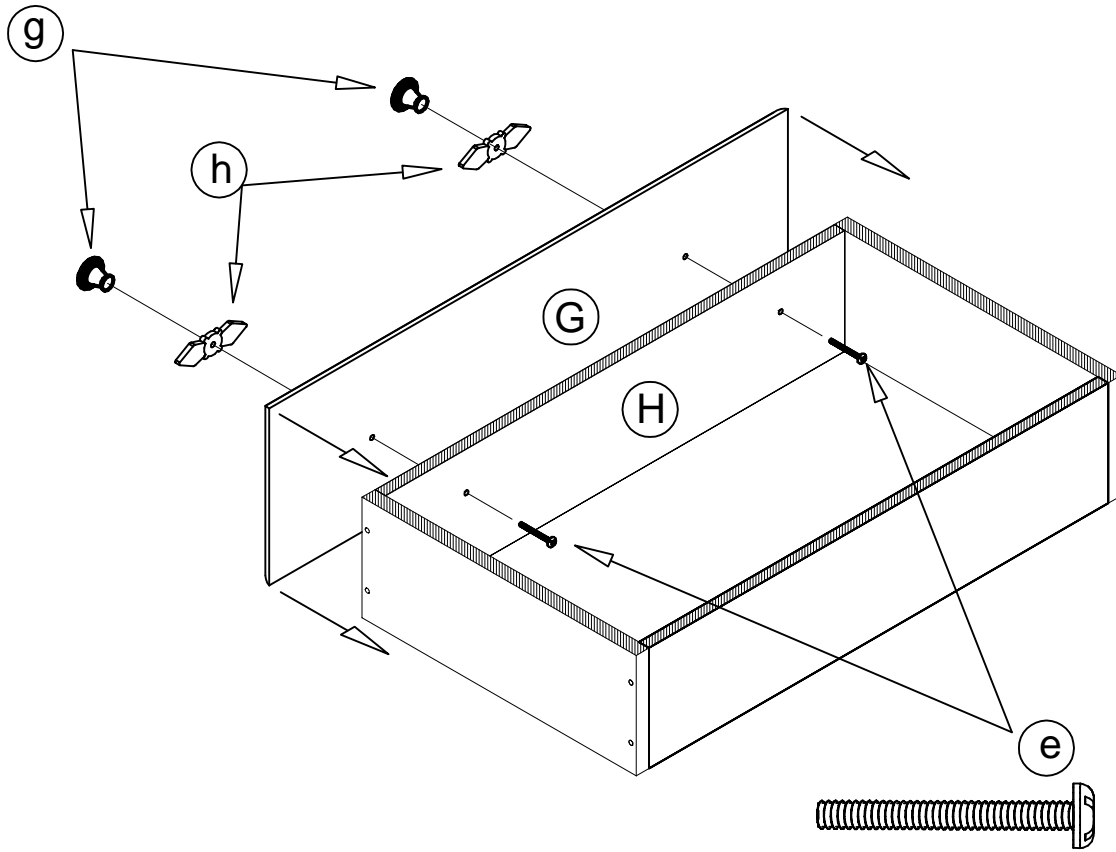

9

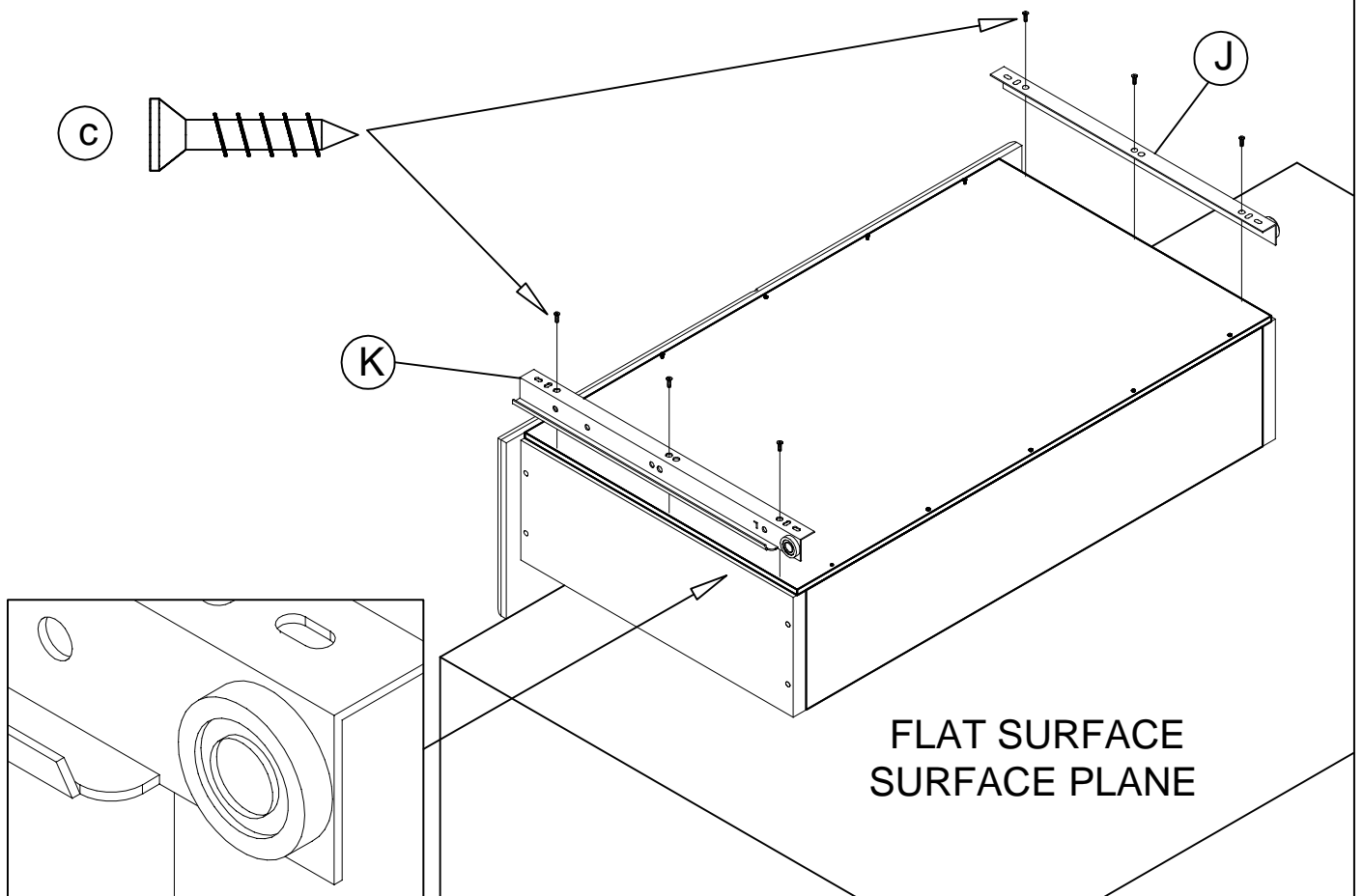

10

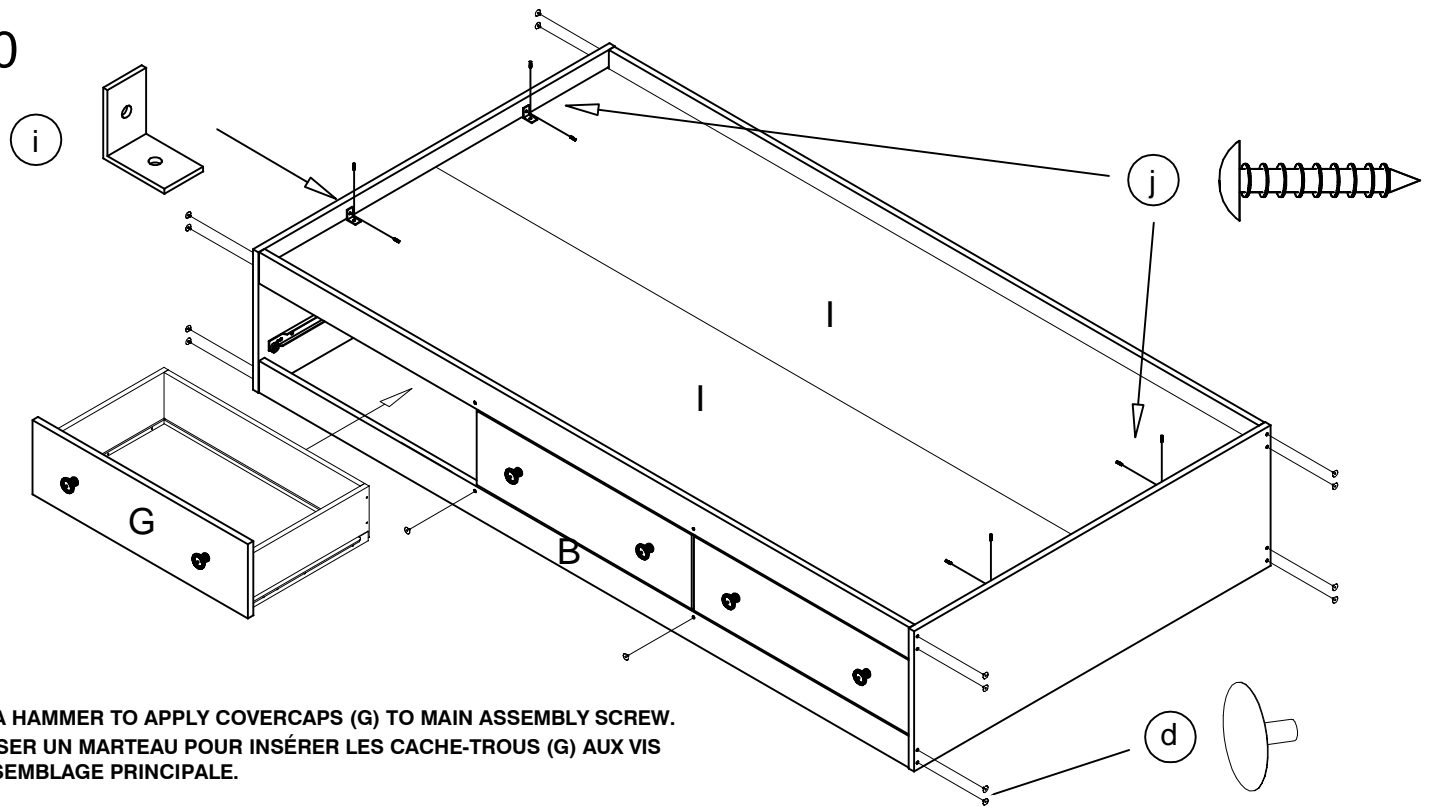

USE A HAMMER TO APPLY COVERCAPS (G) TO MAIN ASSEMBLY SCREW.
UTILISER UN MARTEAU POUR INSÉRER LES CACHE-TROUS (G) AUX VIS
D'ASSEMBLAGE PRINCIPALE.

11

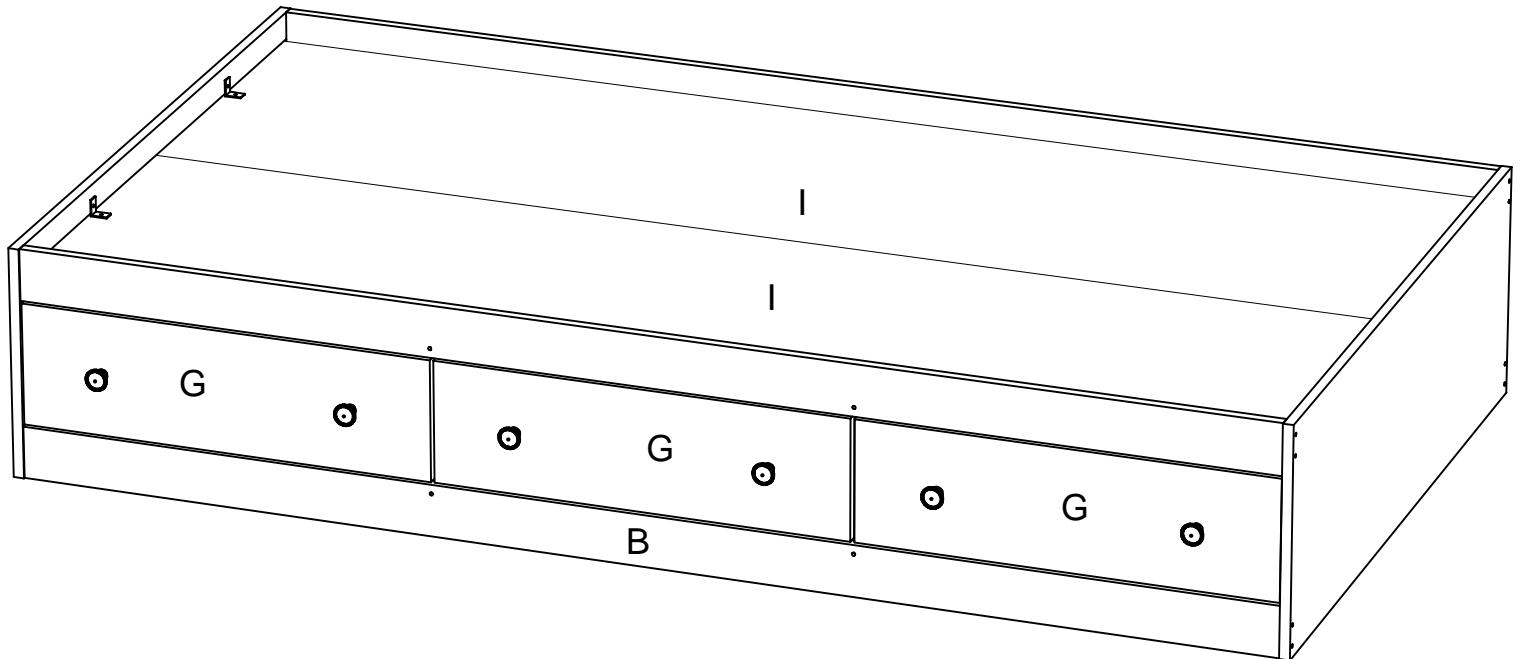

12 (Optional Head Board Assembly)
(En option Assemblée Conseil Chef)

